

# CA



**High pressure, single inlet, centrifugal fans with cast aluminium casing and impeller.**



**Fan:**

- Cast aluminium casing.
- Cast aluminium impeller.

**Motor:**

- IE3 efficiency motors for powers equal to or greater than 0.75 kW except single-phase, 2-speed and 8-pole.
- Class F motors with ball bearings and IP55 protection.
- Three-phase 230/400 V - 50 Hz (up to 4 kW) and 400/690 V - 50 Hz (powers higher than 4 kW).
- Maximum temperature of air to be carried: -20 °C +120 °C.

**Finish:**

- Anti-corrosive finish of polyester resin polymerised at 190 °C, previously degreased with phosphate-free nanotechnological treatment.

**On request:**

- Special windings for different voltages.
- Fan prepared for air transmission of up to 250 °C.
- ATEX-certified Category 2.



Extremely thick aluminium construction to absorb noise and vibrations

### Order code



CA: High pressure, single inlet, centrifugal fans with cast aluminium casing and impeller

Impeller size

Number of motor poles  
2=2900 r/min 50 Hz

T=Three-phase

Motor power (HP)

### Technical characteristics

Model	Speed (r/min)	Maximum admissible current (A)			Installed power (kW)	Maximum flow rate (m <sup>3</sup> /h)	Sound pressure level dB(A)	Approx. weight (kg)	According to ErP
		230 V	400 V	690 V					
CA-134-2T	2710	1.92	1.11		0.37	220	72	10	*
CA-134-2M	2780	2.53			0.37	220	72	10	*
CA-142-2T-0.33	2710	1.29	0.75		0.25	275	73	23	2015
CA-142-2T-0.5	2710	1.92	1.11		0.37	350	73	23	2015
CA-148-2T-0.75	2760	2.57	1.49		0.55	400	74	28	2015
CA-148-2T-1 IE3	2825	2.80	1.62		0.75	490	75	35	2015
CA-148-2T-1.5 IE3	2830	4.03	2.34		1.10	610	76	33	2015
CA-154-2T-1.5 IE3	2830	4.03	2.34		1.10	600	78	47	2015
CA-154-2T-2 IE3	2875	5.34	3.07		1.50	800	79	52	2015
CA-154-2T-3 IE3	2910	7.32	4.21		2.20	1280	80	55	2015
CA-160-2T-2 IE3	2875	5.34	3.07		1.50	500	83	61	2015
CA-160-2T-3 IE3	2910	7.32	4.21		2.20	900	84	63	2015
CA-166-2T-3 IE3	2910	7.32	4.21		2.20	500	84	72	2015
CA-166-2T-4 IE3	2910	10.00	5.77		3.00	950	85	77	2015
CA-166-2T-5.5 IE3	2900	13.00	7.50		4.00	1600	86	85	2015
CA-172-2T-5.5 IE3	2900	13.00	7.50		4.00	1100	87	99	2015
CA-172-2T-7.5 IE3	2930		10.10	5.86	5.50	1710	88	135	2015
CA-172-2T-10 IE3	2930		14.10	8.17	7.50	2300	89	120	2015

\* Equipment not covered by Directive 2009/125/EC

**Acoustic characteristics**

Sound power spectrum Lw(A) in dB(A) per Hz frequency band

	63	125	250	500	1000	2000	4000	8000		63	125	250	500	1000	2000	4000	8000
234	38	51	65	72	80	79	73	64	160-2	54	67	81	88	96	94	88	80
142	39	52	66	73	81	80	74	65	160-3	55	68	82	89	97	95	89	81
148-0.75	43	56	70	77	85	83	77	69	166-3	55	68	82	89	97	95	89	81
148-1	44	57	71	78	86	84	78	70	166-4	56	69	83	90	98	96	90	82
148-1.5	45	58	72	79	87	85	79	71	166-5.5	57	70	84	91	99	97	91	83
154-1.5	47	60	74	81	89	87	81	73	172-5.5	59	72	86	93	101	100	94	85
154-2	48	61	75	82	90	88	82	74	172-7.5	60	73	87	94	102	101	95	86
154-3	49	62	76	83	91	89	83	75	172-10	61	74	88	95	103	102	96	87



**Erp. (Energy Related Products)**

Information on Directive 2009/125/EC can be downloaded from the SODECA website or the QuickFan selector programme.

**Dimensions mm**

**CA-234**

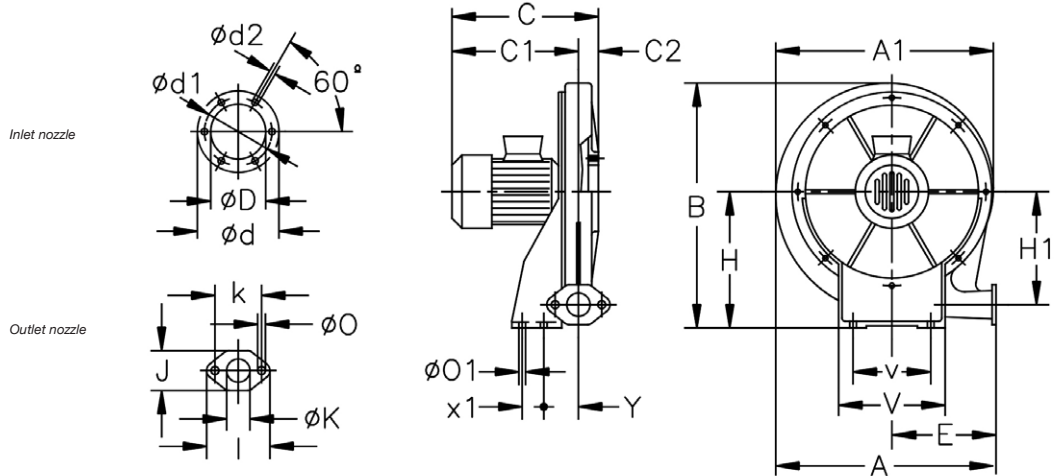

	A	A1	B	C	C1	C2	øD	ød	ød1	ød2	E	H	H1	I	J	øK	k	øO	øO1	V	v	x1	Y
CA-234-2T-0.33	376	381	415	261	236.5	24.5	98	130	115	M4	175	225	187	98	63	40	78	9	9	180	120	40	94
CA-234-2M-0.33	376	381	415	266	241.5	24.5	98	130	115	M4	175	225	187	98	63	40	78	9	9	180	120	40	94

**CA-142...148**

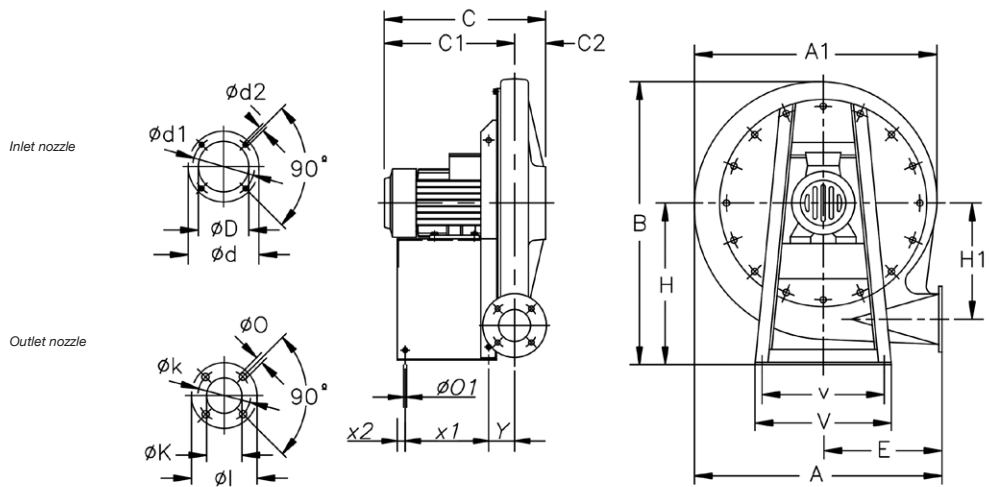

	A	A1	B	C	C1	C2	øD	ød	ød1	ød2	E	H	H1	øI	øK	øk	øO	øO1	V	v	x1	x2	Y
CA-142-2T-0.33	494	488	540	261	215	46	90	160	130	M8	240	301	235	120	60	90	11	12	300	270	130	20	47.5
CA-142-2T-0.5	494	488	540	291	245	46	90	160	130	M8	240	301	235	120	60	90	11	12	300	270	130	20	47.5
CA-148-2T-0.75	563	557.5	639	308.5	251.5	57	100	170	140	M8	270	360	269.5	150	73	110	11	12	330	290	140	20	60
CA-148-2T-1	563	557.5	639	331	274	57	100	170	140	M8	270	360	269.5	150	73	110	11	12	330	290	140	20	60
CA-148-2T-1.5	563	557.5	639	331	274	57	100	170	140	M8	270	360	269.5	150	73	110	11	12	330	290	140	20	60

## Dimensions mm

CA-154...172

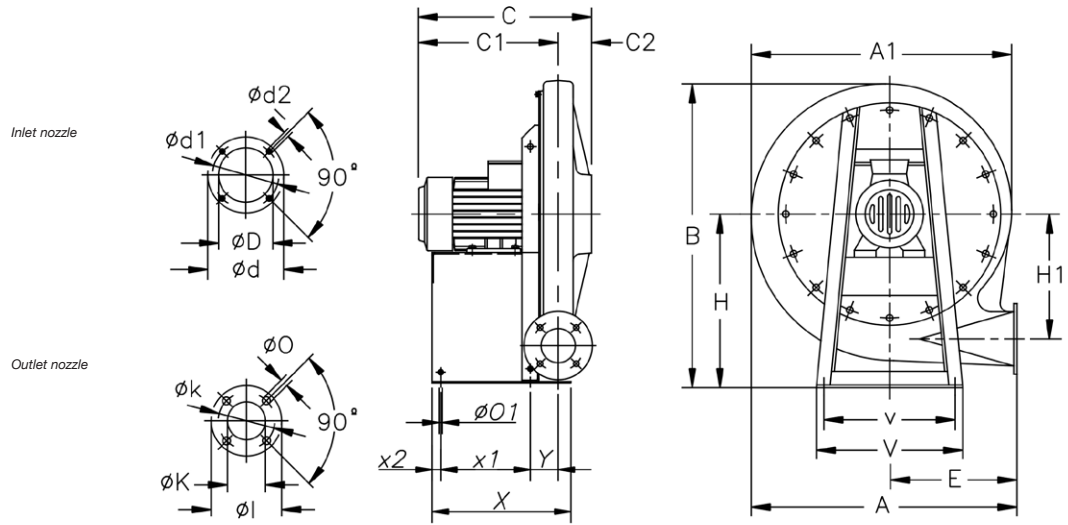

	A	A1	B	C	C1	C2	ØD	Ød	Ød1	Ød2	E	H	H1	Øl	ØK	Øk	ØO	ØO1	V	v	X	x1	x2	Y
CA-154-2T-1.5	630	625	708	351	273	78	115	183	155	M10	300	395	308	160	80	120	13	12	356	320	325	210	20	65
CA-154-2T-2	630	625	708	405	327	79.5	115	183	155	M10	300	395	308	160	80	120	13	12	356	320	325	210	20	65
CA-154-2T-3	630	625	708	396	316.5	79.5	115	183	155	M10	300	395	308	160	80	120	13	12	356	320	325	210	20	65
CA-160-2T-2	700	689	785	415	329.5	85.5	130	230	192	M10	336	440	338	160	85	120	13	12	373	322	344	220	23	68.5
CA-160-2T-3	708	699	785	406	316	90	130	230	192	M10	336	440	338	160	85	120	13	12	373	322	344	220	23	68.5
CA-166-2T-3	759	752	866	385	307.5	77.5	140	230	200	M10	364	490	372	160	85	120	13	12	450	400	370	245	23	67.5
CA-166-2T-4	759	752	866	435	357.5	77.5	140	230	200	M10	364	490	372	160	85	120	13	12	450	400	370	245	23	67.5
CA-166-2T-5.5	759	752	866	458	380	77.5	140	230	200	M10	364	490	372	160	85	120	13	12	450	400	390	265	23	70.5
CA-172-2T-5.5	818	813	923	469	388	80	148	230	198	M10	390	516	404	175	90	140	13	12	450	400	395	260	25	78
CA-172-2T-7.5	818	813	923	507	426	80	148	230	200	M10	390	516	404	175	90	140	13	12	450	400	435	300	25	78
CA-172-2T-10	818	813	923	507	426	80	148	230	200	M10	390	516	404	175	90	140	13	12	450	400	435	300	25	78

## Characteristic curves

Q= Flow rate in m<sup>3</sup>/h, m<sup>3</sup>/s and cfm

Pe= Static pressure in mm H<sub>2</sub>O, Pa and inwg

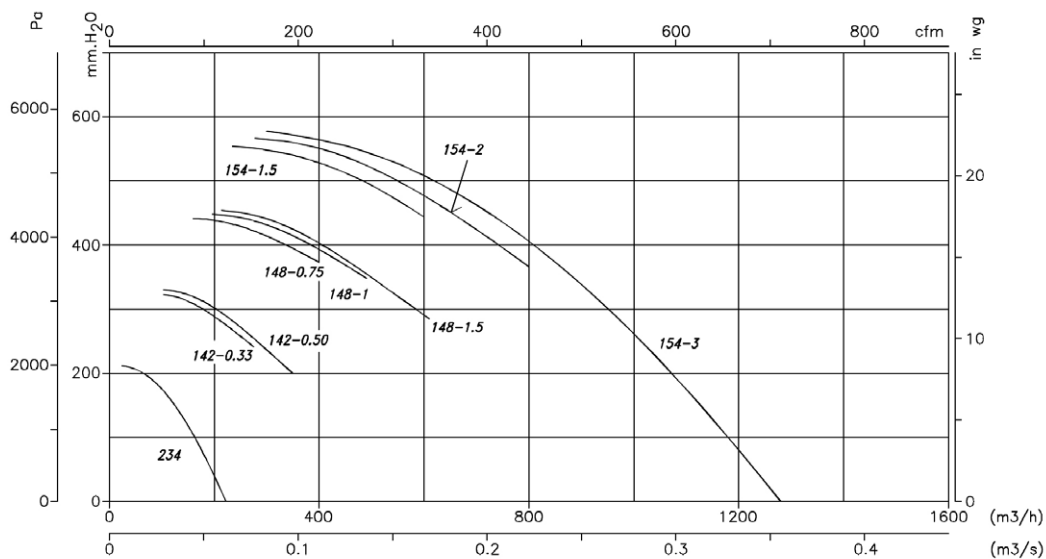

**Characteristic curves**

Q= Flow rate in m<sup>3</sup>/h, m<sup>3</sup>/s and cfm

Pe= Static pressure in mm H<sub>2</sub>O, Pa and inwg

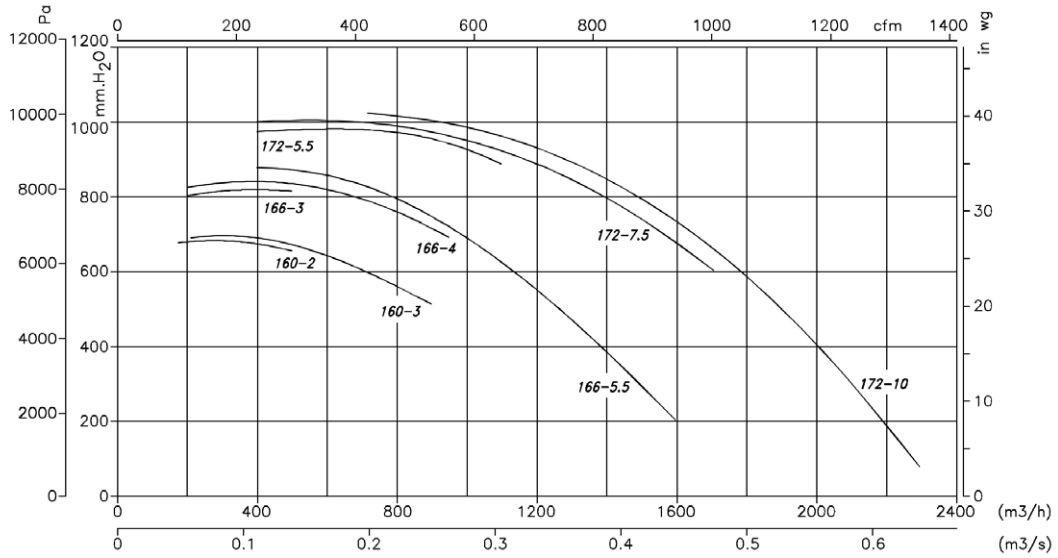

**Orientation**

Standard supply LG 270

LG 180 positions on request and with special anchoring measurements.



**Accessories**

See accessories section.

