

CAS CAS-S

CAS: Single inlet, high pressure centrifugal fans with sheet steel casing and impeller

CAS-S: Single inlet, high pressure centrifugal fans with sheet steel casing and impeller, equipped with acoustic attenuator



Fan:

- Sheet steel casing.
- Backward curved impeller in galvanized sheet steel, except models 242, 248, 254, 260, 640, 645 and 650 in cast aluminum impeller.
- CAS-S: Acoustic attenuator with a hexagonal profile incorporated in the suction inlet of the fan. Its design allows adjusting the air flow at the fan inlet.

Motor:

- Motors with IE3 efficiency for powers equal to or greater than 0.75kW, except single-phase, 2-speed and 8-pole.
- Class F motors with ball bearings and IP55 protection.
- Three-phase 230/400 V 50 Hz (up to 4 kW) and 400/690 V 50 Hz (powers greater than 4 kW).
- Maximum temperature of air to be carried: -20 °C +120 °C.

Finishing:

- Anti-corrosive finish in polyester resin, polymerised at 190 °C, after degreasing with phosphate-free nanotechnology treatment.

On request:

- Special windings for different voltages.
- Fan prepared to transport air up to +250 °C.
- Stainless steel fan.
- ATEX certified Category 2.



Extremely robust motor support bench

Order code



CAS: Single inlet, high pressure centrifugal fans with sheet steel casing and impeller

Impeller size

Number of motor poles
2=2900 r/min 50 Hz

T=Three-phase

Motor power (HP)

CAS-S: Single inlet, high pressure centrifugal fans with sheet steel casing and impeller, equipped with acoustic attenuator

Technical characteristics

Model	Speed (r/min)	Maximum admissible current (A)			Installed power (kW)	Maximum flow rate (m³/h)	Sound pressure level dB(A)		Approx. weight (Kg)		According ErP
		230V	400V	690V			CAS	CAS-S	CAS	CAS-S	
CAS CAS-S 242-2T-0.33	2710	1.29	0.75	0.25	450	73	67	30	33	2015	
CAS CAS-S 242-2T-0.5	2710	1.92	1.11	0.37	650	73	67	31	34	2015	
CAS CAS-S 248-2T-1 IE3	2825	2.80	1.62	0.75	500	75	69	50	53	2015	
CAS CAS-S 248-2T-1.5 IE3	2830	4.03	2.34	1.1	990	76	70	48	51	2015	
CAS CAS-S 254-2T-2 IE3	2875	5.34	3.07	1.5	800	78	72	65	68	2015	
CAS CAS-S 254-2T-3 IE3	2910	7.32	4.21	2.2	1300	80	73	68	71	2015	

INDUSTRIAL FANS · GENERAL CATALOGUE ·

Technical characteristics

Model	Speed (r/min)	Maximum admissible current (A)			Installed power (kW)	Maximum flow rate (m³/h)	Sound pressure level dB(A)		Approx. weight (Kg)		According ErP
		230V	400V	690V			CAS	CAS-S	CAS	CAS-S	
CAS CAS-S 242-2T-0.33	2710	1.29	0.75		0.25	450	73	67	30	33	2015
CAS CAS-S 242-2T-0.5	2710	1.92	1.11		0.37	650	73	67	31	34	2015
CAS CAS-S 248-2T-1 IE3	2825	2.80	1.62		0.75	500	75	69	50	53	2015
CAS CAS-S 248-2T-1.5 IE3	2830	4.03	2.34		1.1	990	76	70	48	51	2015
CAS CAS-S 254-2T-2 IE3	2875	5.34	3.07		1.5	800	78	72	65	68	2015
CAS CAS-S 254-2T-3 IE3	2910	7.32	4.21		2.2	1300	80	73	68	71	2015
CAS CAS-S 260-2T-3 IE3	2910	7.32	4.21		2.2	900	79	72	83	88	2015
CAS CAS-S 463-2T-5.5 IE3	2900	13.00	7.50		4	1150	82	75	98	103	2015
CAS CAS-S 463-2T-7.5 IE3	2930		10.10	5.86	5.5	2000	83	76	119	124	2015
CAS CAS-S 467-2T-7.5 IE3	2930		10.10	5.86	5.5	1550	84	77	141	146	2015
CAS CAS-S 467-2T-10 IE3	2930		14.10	8.17	7.5	2600	85	78	119	124	2015
CAS CAS-S 571-2T-10 IE3	2930		14.10	8.17	7.5	2000	86	78	140	145	2015
CAS CAS-S 571-2T-15 IE3	2945		20.00	11.60	11	3450	87	79	207	212	2015
CAS CAS-S 640-2T-2 IE3	2875	5.34	3.07		1.5	2600	77	71	55	60	2015
CAS CAS-S 645-2T-3 IE3	2910	7.32	4.21		2.2	2000	76	70	67	75	2015
CAS CAS-S 645-2T-4 IE3	2910	10.00	5.77		3	3000	81	74	73	81	2015
CAS CAS-S 650-2T-5.5 IE3	2900	13.00	7.50		4	3500	81	74	98	106	2015
CAS CAS-S 650-2T-7.5 IE3	2930		10.10	5.86	5.5	4750	83	76	119	127	2015
CAS CAS-S 852-2T-7.5 IE3	2930		10.10	5.86	5.5	3500	81	74	119	127	2015
CAS CAS-S 852-2T-10 IE3	2930		14.10	8.17	7.5	5500	85	78	97	105	2015
CAS CAS-S 856-2T-15 IE3	2945		20.00	11.60	11	7500	85	78	190	200	2015
CAS CAS-S 863-2T-15 IE3	2945		20.00	11.60	11	4000	84	77	200	210	2015
CAS CAS-S 863-2T-20 IE3	2945		27.70	16.10	15	7000	86	78	203	213	2015
CAS CAS-S 971-2T-30 IE3	2950		39.70	23.00	22	8100	88	80	324	334	2015
CAS CAS-S 971-2T-40 IE3	2960		54.50	31.60	30	12000	89	81	410	420	2015
CAS CAS-S 790-2T-20 IE3	2945		27.70	16.10	15	2100	88	80	269	274	Excluded
CAS CAS-S 980-2T-30 IE3	2950		39.70	23.00	22	4800	87	79	340	355	2015
CAS CAS-S 990-2T-50 IE3	2960		67.80	39.30	37	6000	90	82	480	495	Excluded
CAS CAS-S 1080-2T-40 IE3	2960		54.50	31.60	30	5400	88	80	450	465	Excluded
CAS CAS-S 1090-2T-60 IE3	2960		77.50	44.90	45	6000	91	83	620	635	Excluded

* Equipment not covered by Directive 2009/125/EC

Erp. (Energy Related Products)

Information on Directive 2009/125/EC can be downloaded from the SODECA website or the QuickFan selector programme.

Acoustic characteristics

Sound power spectrum Lw(A) in dB(A) per Hz frequency band.

CAS

	63	125	250	500	1000	2000	4000	8000
242	50	61	67	76	83	82	79	72
248-1	52	63	69	78	85	84	81	74
248-1.5	53	64	70	79	86	85	82	75
254-2	57	68	73	83	90	89	86	79
254-3	56	68	76	85	90	92	89	82
260-3	55	71	71	85	90	90	87	80
463-5.5	57	69	82	91	93	93	89	80
463-7.5	58	70	83	92	94	94	90	81
467-7.5	69	74	83	95	95	97	93	85
467-10	70	75	84	96	96	98	94	86
571-10	64	76	86	96	99	99	94	86
571-15	65	77	87	97	100	100	95	87
640	56	67	75	82	88	84	83	76
645-3	55	66	74	81	87	83	82	75
645-4	55	66	77	86	90	91	87	79

	63	125	250	500	1000	2000	4000	8000
650-5.5	59	75	84	90	93	90	85	78
650-7.5	52	68	81	91	96	93	85	78
852-7.5	68	72	82	88	92	92	89	84
852-10	68	76	86	93	96	96	92	84
856	63	76	90	96	96	94	90	84
863-15	67	81	87	96	96	95	92	87
863-20	69	81	92	99	98	95	93	87
971-30	68	82	91	103	99	97	94	90
971-40	68	83	97	102	102	99	95	88
790	73	77	88	99	105	96	89	83
980	61	70	76	91	105	97	94	90
990	64	73	79	94	108	100	97	93
1080	62	71	77	92	106	98	95	91
1090	65	77	80	95	109	101	98	94

CAS-S

Sound power spectrum Lw(A) in dB(A) per Hz frequency band.

	63	125	250	500	1000	2000	4000	8000
242	44	55	61	70	77	76	73	66
248-1	46	57	63	72	79	78	75	68
248-1.5	47	58	64	73	80	79	76	69
254-2	51	62	67	77	84	83	80	73
254-3	49	61	69	78	83	85	82	75
260-3	48	64	64	78	83	83	80	73
463-5.5	50	62	75	84	86	86	82	73
463-7.5	51	63	76	85	87	87	83	74
467-7.5	62	67	76	88	88	90	86	78
467-10	63	68	77	89	89	91	87	79
571-10	56	68	78	88	91	91	86	78
571-15	57	69	79	89	92	92	87	79
640	50	61	69	76	82	78	77	70
645-3	49	60	68	75	81	77	76	69
645-4	48	59	70	79	83	84	80	72

	63	125	250	500	1000	2000	4000	8000
650-5.5	52	68	77	83	86	83	78	71
650-7.5	45	61	74	84	89	86	78	71
852-7.5	61	65	75	81	85	85	82	77
852-10	61	69	79	86	89	89	85	77
856	56	69	83	89	89	87	83	77
863-15	60	74	80	89	89	88	85	80
863-20	61	73	84	91	90	87	85	79
971-30	60	74	83	95	91	89	86	82
971-40	60	75	89	94	94	91	87	80
790	65	69	80	91	97	88	81	75
980	53	62	68	83	97	89	86	82
990	56	65	71	86	100	92	89	85
1080	54	63	69	84	98	90	87	83
1090	57	66	72	87	101	93	90	86

INDUSTRIAL FANS · GENERAL CATALOGUE ·

Dimensions mm

CAS-242...971

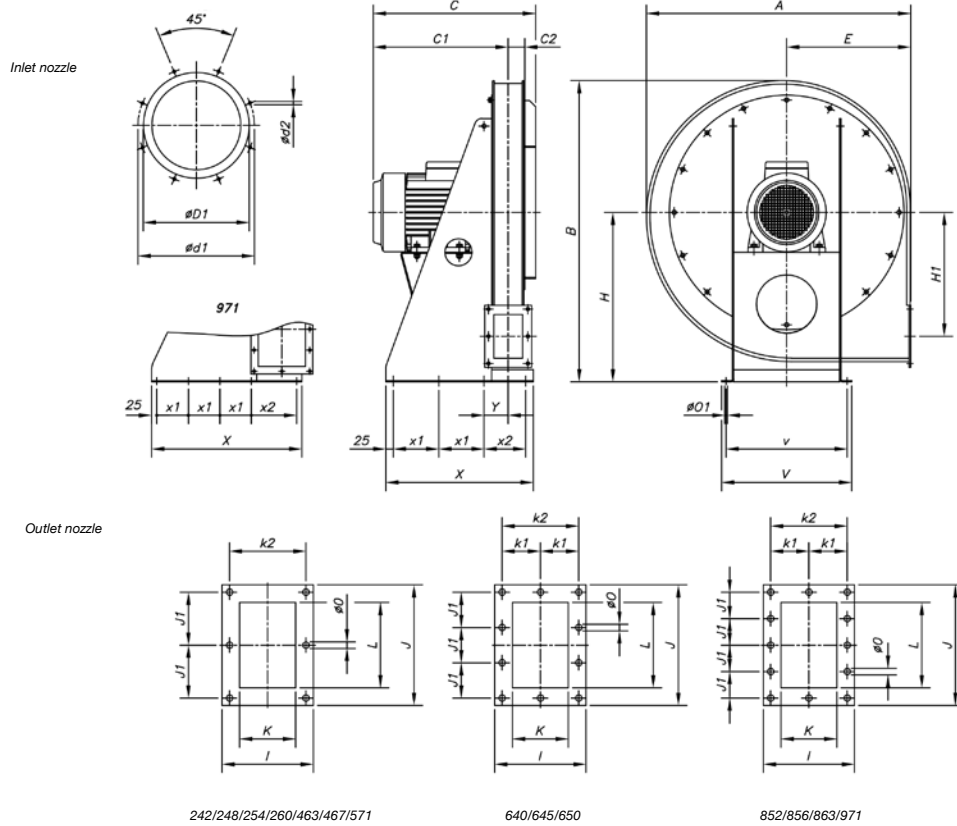

242/248/254/260/463/467/571

640/645/650

852/856/863/971

	A	B	C	C1	C2	øD1	ød1	ød2	E	H	H1	I	J	J1	K	k1	k2	L	øO	øO1	V	v	X	x1	x2	Y
CAS-242-2T-0.33	576	662	299	236	33	100	130	M8	270	375	270	120	155	65	60	-	95	95	11	12	305	275	260	75	-	61
CAS-242-2T-0.5	576	662	319	256	33	100	130	M8	270	375	270	120	155	65	60	-	95	95	11	12	305	275	260	75	-	61
CAS-248-2T-1/1.5	639	728	343	277	36	112	140	M8	300	410	297	126	165	70	66	-	101	105	11	12	320	290	300	90	-	64
CAS-254-2T-2	699	788	413	342.5	40.5	125	155	M8	330	440	322	135	175	75	75	-	110	115	11	14	340	310	330	100	-	68.5
CAS-254-2T-3	699	788	413	342.5	40.5	125	155	M8	330	440	322	135	175	75	75	-	110	115	11	14	340	310	330	100	-	68.5
CAS-260-2T-3	782	875	419	343	46	150	175	M8	370	485	362	145	185	80	85	-	120	125	11	14	380	350	370	115	-	73.5
CAS-463-2T-5.5	782	875	459	383.5	45.5	200	240	M8	370	485	362	145	185	80	85	-	120	125	11	14	380	350	370	115	-	73.5
CAS-463-2T-7.5	782	875	517	441.5	45.5	200	240	M8	370	485	362	145	185	80	85	-	120	125	11	14	380	350	370	115	-	73.5
CAS-467-2T-7.5/10	833	945	524	436	48	224	258	M8	390	530	395	150	190	82.5	90	-	125	130	11	14	405	375	300	125	-	76
CAS-571-2T-10	873	995	536	445.5	50.5	250	275	M8	410	560	410	155	205	90	95	-	130	145	11	14	430	400	350	150	-	79.5
CAS-571-2T-15	873	995	693	602.5	50.5	250	275	M8	410	560	410	155	205	90	95	-	130	145	11	14	430	400	410	180	-	79.5
CAS-640-2T-2	639	728	446	350.5	65.5	250	275	M8	300	410	250	185	260	78	125	80	160	200	11	14	340	310	350	100	-	93.5
CAS-645-2T-3	699	788	461	358	73	250	275	M8	330	440	267.5	200	284	86	140	87.5	175	224	11	14	380	350	380	115	-	101
CAS-645-2T-4	699	788	503	400	73	250	275	M8	330	440	267.5	200	284	86	140	87.5	175	224	11	14	380	350	380	115	-	101
CAS-650-2T-5.5	782	875	534	421	83	250	275	M8	370	485	300	220	310	95	160	97.5	195	250	11	14	405	375	490	125	190	111
CAS-650-2T-7.5	782	875	572	459	83	250	275	M8	370	485	300	220	310	95	160	97.5	195	250	11	14	405	375	490	125	190	111
CAS-852-2T-7.5/10	833	945	603	468.5	94.5	280	310	M8	390	530	320	240	340	78	180	107.5	215	280	11	14	430	400	540	150	190	122
CAS-856-2T-15	833	945	730	597	93	355	395	M8	390	530	320	240	340	78	180	107.5	215	280	11	14	430	400	600	180	190	122
CAS-863-2T-15/20	873	995	728	585	103	355	410	M8	410	560	325	260	375	87.5	200	117.5	235	315	11	14	430	400	620	180	210	132
CAS-971-2T-30	1012	1170	881	720	116	400	450	M10	460	670	420	294	425	100	224	132	264	355	11	14	550	510	715	150	215	145
CAS-971-2T-40	1012	1170	948	787	116	400	450	M10	460	670	420	294	425	100	224	132	264	355	11	14	550	510	715	150	215	145

SMALL SERIES

Dimensions mm

CAS-790...1090

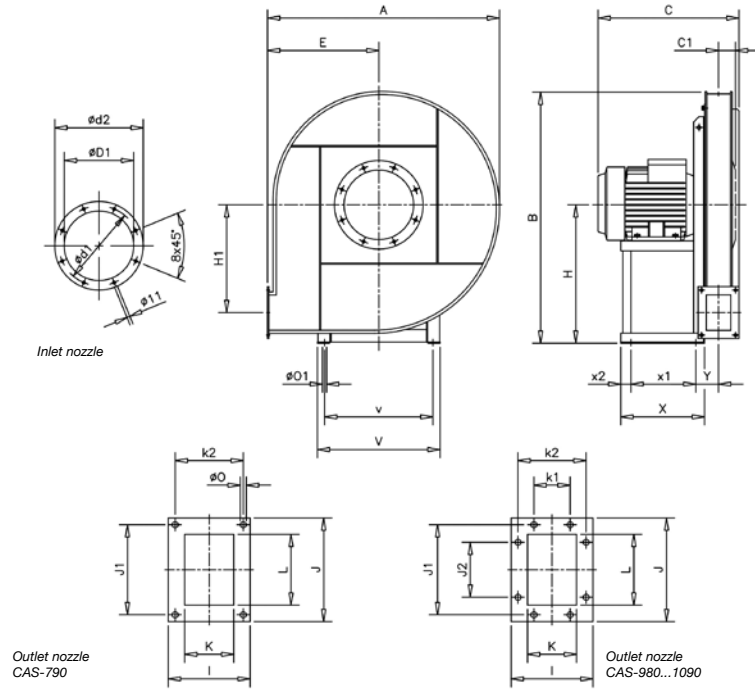

	A	B	C	C1	$\phi D1$	$\phi D1$	$\phi D2$	E	H	H1	I	J	J1	J2	K	k1	k2	L	ϕO	$\phi O1$	V	v	X	x1	x2	Y
CAS-790-2T-20	1095	1175	680	56	185	219	255	530	630	520	140	172	140	-	80	-	112	112	9	14	440	400	425	340	30	103
CAS-980-2T-30	1120	1250	740	90	255	292	325	530	710	530	210	270	241	112	140	112	182	200	11.5	14	500	450	470	370	35	143
CAS-990-2T-50	1270	1410	840	100	286	332	366	600	800	600	230	294	265	112	160	112	200	224	11.5	16	570	510	500	385	40	165
CAS-1080-2T-40	1120	1250	815	90	255	292	325	530	710	530	210	270	241	112	140	112	182	200	11.5	16	570	510	500	385	40	153
CAS-1090-2T-60	1270	1410	920	100	286	332	366	600	800	600	230	294	265	112	160	112	200	224	11.5	19	626	565	550	425	40	175

INDUSTRIAL FANS · GENERAL CATALOGUE ·

Dimensions mm

CAS-S-242...971

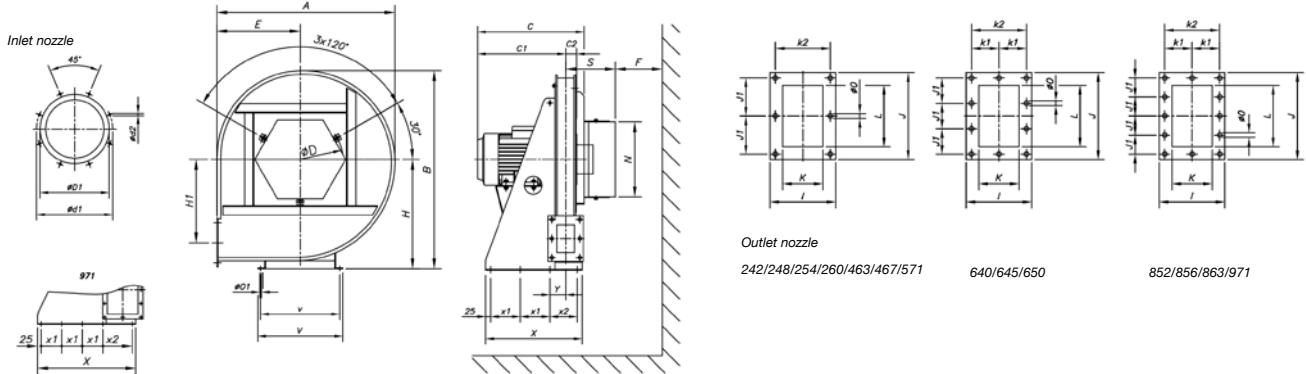

	A	B	C	C1	C2	øD1	ød1	øD2	ØD	N	S	F	E	H	H1	I
CAS-S-242-2T-0.33	576	662	299	236	33	100	130	M8	276	255	170	150	270	375	270	120
CAS-S-242-2T-0.5	576	662	319	256	33	100	130	M8	276	255	170	150	270	375	270	120
CAS-S-248-2T-1/1.5	639	728	343	277	36	112	140	M8	276	255	218	150	300	410	297	126
CAS-S-254-2T-2	699	788	413	342.5	40.5	125	155	M8	276	255	225	150	330	440	322	135
CAS-S-254-2T-3	699	788	413	342.5	40.5	125	155	M8	276	255	225	150	330	440	322	135
CAS-S-260-2T-3	782	875	419	343	46	150	175	M8	371	350	230	150	370	485	362	145
CAS-S-463-2T-5.5	782	875	459	383.5	45.5	200	240	M8	371	350	230	150	370	485	362	145
CAS-S-463-2T-7.5	782	875	517	441.5	45.5	200	240	M8	371	350	230	150	370	485	362	145
CAS-S-467-2T-7.5/10	833	945	524	436	48	224	258	M8	371	350	235	150	390	530	395	150
CAS-S-571-2T-10	873	995	536	445.5	50.5	250	275	M8	371	350	240	150	410	560	410	155
CAS-S-571-2T-15	873	995	693	602.5	50.5	250	275	M8	371	350	240	150	410	560	410	155
CAS-S-640-2T-2	639	728	446	350.5	65.5	250	275	M8	371	350	255	150	300	410	250	185
CAS-S-645-2T-3	699	788	461	358	73	250	275	M8	581	560	260	200	330	440	267.5	200
CAS-S-645-2T-4	699	788	503	400	73	250	275	M8	581	560	260	200	330	440	267.5	200
CAS-S-650-2T-5.5	782	875	534	421	83	250	275	M8	661	560	270	200	370	485	300	220
CAS-S-650-2T-7.5	782	875	572	459	83	250	275	M8	661	560	270	200	370	485	300	220
CAS-S-852-2T-7.5/10	833	945	603	468.5	94.5	280	310	M8	661	560	280	200	390	530	320	240
CAS-S-856-2T-15	833	945	730	597	93	355	395	M8	683	655	280	200	390	530	320	240
CAS-S-863-2T-15/20	873	995	728	585	103	355	410	M8	758	655	290	200	410	560	325	260
CAS-S-971-2T-30	1012	1170	881	720	116	400	450	M10	759	655	305	200	460	670	420	294
CAS-S-971-2T-40	1012	1170	948	787	116	400	450	M10	759	655	305	200	460	670	420	294

	J	J1	K	k1	k2	L	øO	øO1	V	v	X	x1	x2	Y
CAS-S-242-2T-0.33	155	65	60	-	95	95	11	12	305	275	260	75	-	61
CAS-S-242-2T-0.5	155	65	60	-	95	95	11	12	305	275	260	75	-	61
CAS-S-248-2T-1/1.5	165	70	66	-	101	105	11	12	320	290	300	90	-	64
CAS-S-254-2T-2	175	75	75	-	110	115	11	14	340	310	330	100	-	68.5
CAS-S-254-2T-3	175	75	75	-	110	115	11	14	340	310	330	100	-	68.5
CAS-S-260-2T-3	185	80	85	-	120	125	11	14	380	350	370	115	-	73.5
CAS-S-463-2T-5.5	185	80	85	-	120	125	11	14	380	350	370	115	-	73.5
CAS-S-463-2T-7.5	185	80	85	-	120	125	11	14	380	350	370	115	-	73.5
CAS-S-467-2T-7.5/10	190	82.5	90	-	125	130	11	14	405	375	300	125	-	76
CAS-S-571-2T-10	205	90	95	-	130	145	11	14	430	400	350	150	-	79.5
CAS-S-571-2T-15	205	90	95	-	130	145	11	14	430	400	410	180	-	79.5
CAS-S-640-2T-2	260	78	125	80	160	200	11	14	340	310	350	100	-	93.5
CAS-S-645-2T-3	284	86	140	87.5	175	224	11	14	380	350	380	115	-	101
CAS-S-645-2T-4	284	86	140	87.5	175	224	11	14	380	350	380	115	-	101
CAS-S-650-2T-5.5	310	95	160	97.5	195	250	11	14	405	375	490	125	190	111
CAS-S-650-2T-7.5	310	95	160	97.5	195	250	11	14	405	375	490	125	190	111
CAS-S-852-2T-7.5/10	340	78	180	107.5	215	280	11	14	430	400	540	150	190	122
CAS-S-856-2T-15	340	78	180	107.5	215	280	11	14	430	400	600	180	190	122
CAS-S-863-2T-15/20	375	87.5	200	117.5	235	315	11	14	430	400	620	180	210	132
CAS-S-971-2T-30	425	100	224	132	264	355	11	14	550	510	715	150	215	145
CAS-S-971-2T-40	425	100	224	132	264	355	11	14	550	510	715	150	215	145

SMALL SERIES

Dimensions mm

CAS-S-790...1090

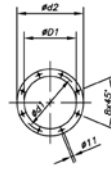
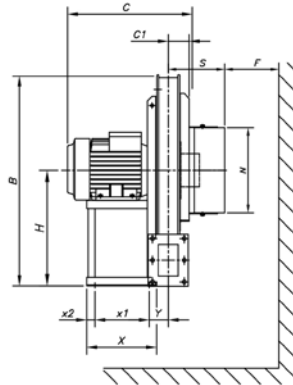
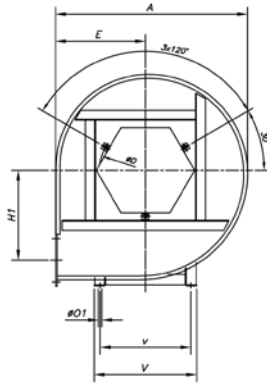

Inlet nozzle

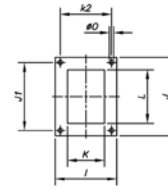

Outlet nozzle
680/790

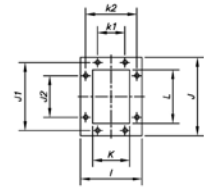

Outlet nozzle
980...1090

	A	B	C	C1	øD1	ød1	ød2	ØD	N	S	F	E	H	H1	I
CAS-S-790-2T-20	1095	1175	680	56	185	219	255	371	350	259	200	530	630	520	140
CAS-S-980-2T-30	1120	1250	740	90	255	292	325	581	560	290	200	530	710	530	210
CAS-S-990-2T-50	1270	1410	840	100	286	332	366	581	560	300	200	600	800	600	230
CAS-S-1080-2T-40	1120	1250	815	90	255	292	325	581	560	290	200	530	710	530	210
CAS-S-1090-2T-60	1270	1410	920	100	286	332	366	581	560	300	200	600	800	600	230

	J	J1	J2	K	k1	k2	L	øO	øO1	V	v	X	x1	x2	Y
CAS-S-790-2T-20	172	140	-	80	-	112	112	9	14	440	400	425	340	30	103
CAS-S-980-2T-30	270	241	112	140	112	182	200	11.5	14	500	450	470	370	35	143
CAS-S-990-2T-50	294	265	112	160	112	200	224	11.5	16	570	510	500	385	40	165
CAS-S-1080-2T-40	270	241	112	140	112	182	200	11.5	16	570	510	500	385	40	153
CAS-S-1090-2T-60	294	265	112	160	112	200	224	11.5	19	626	565	550	425	40	175

INDUSTRIAL FANS · GENERAL CATALOGUE ·

Characteristic curves

Q= Flow rate in m³/h, m³/s and cfm Pe= Static pressure in mm H₂O, Pa and inwg

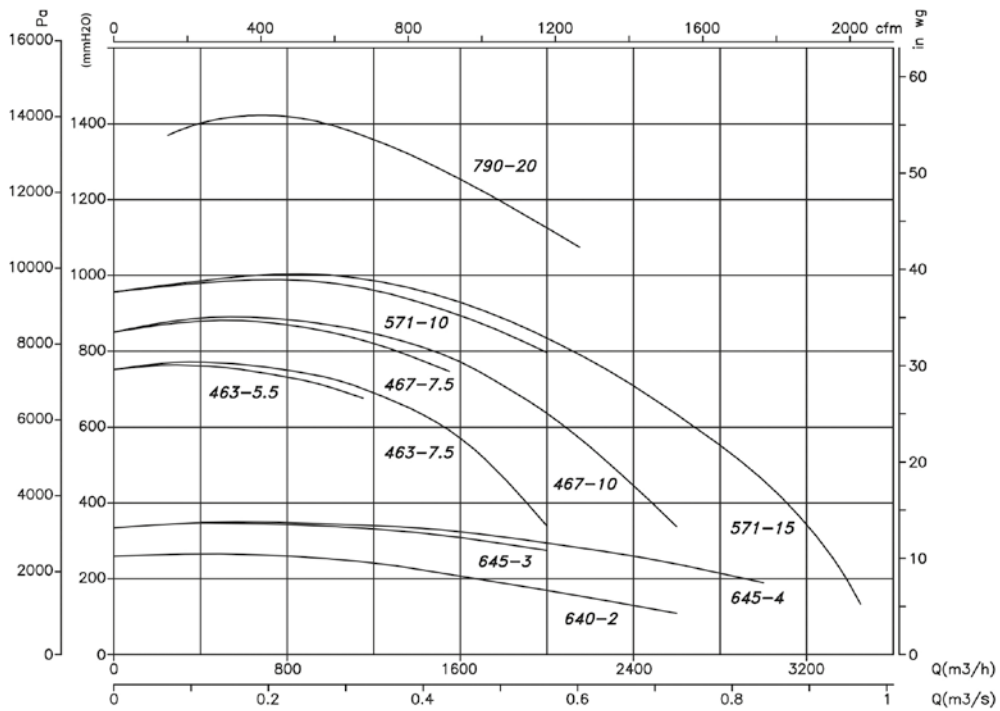
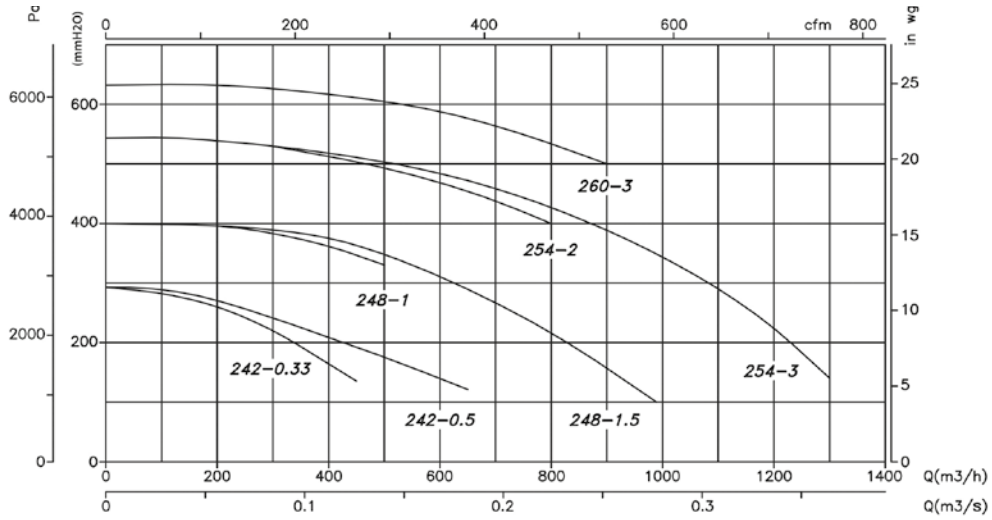

SMALL SERIES

Accessories

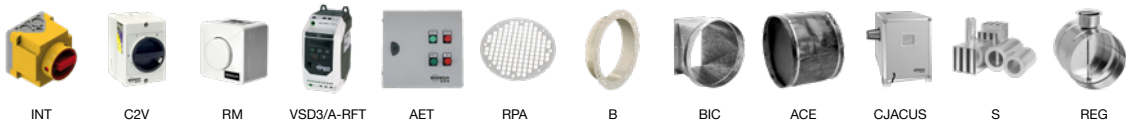

Characteristic curves

Q= Flow rate in m³/h, m³/s and cfm Pe= Static pressure in mm H₂O, Pa and inwg

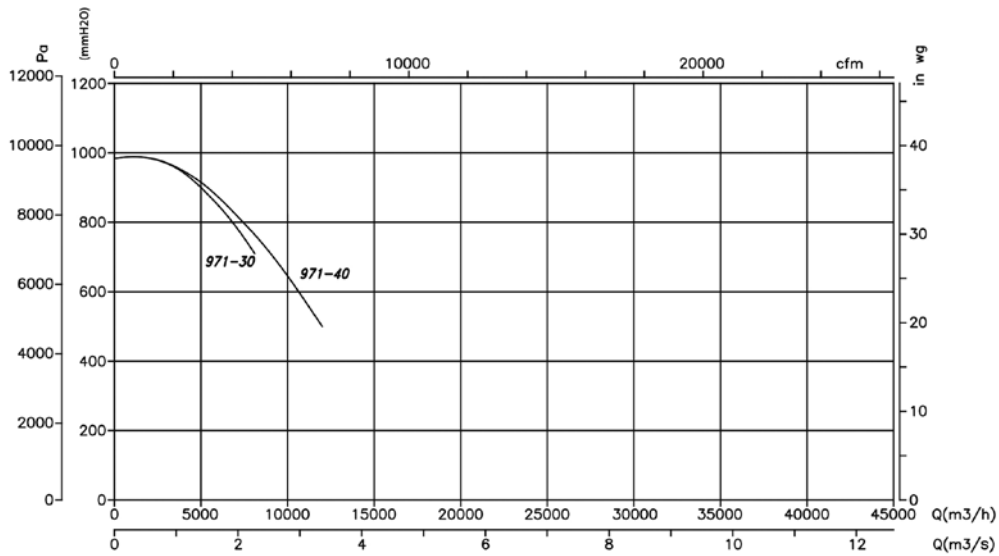
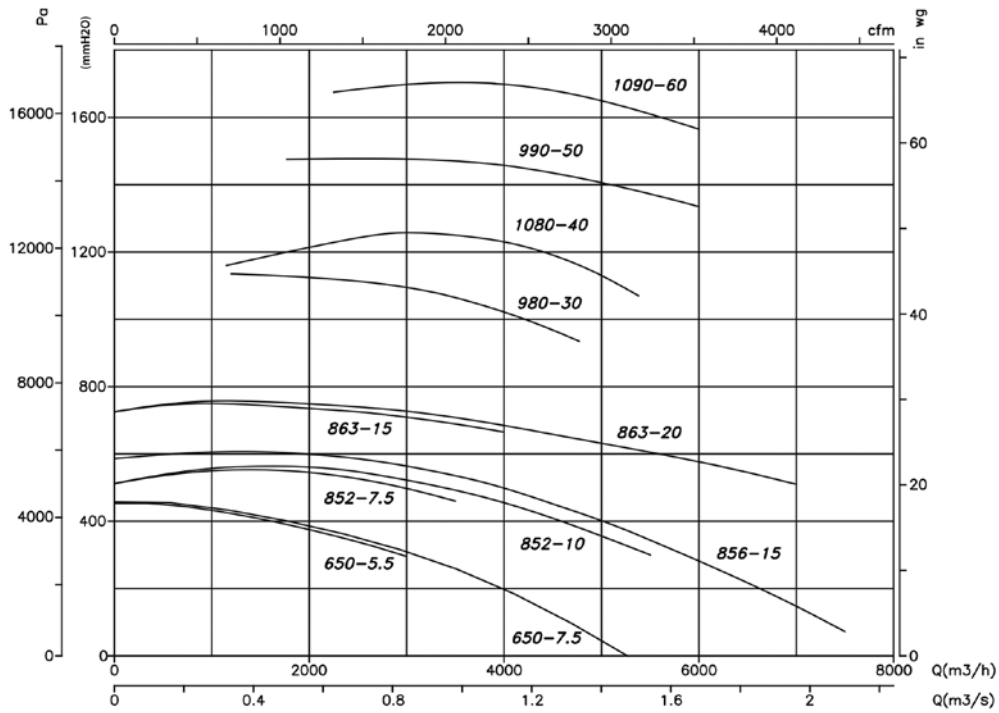

SMALL SERIES

Orientations

Standard supply LG 270
LG 180 position on request and with special anchoring measurements.

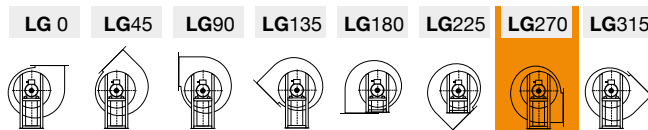

Supply on request
RD 180 positions with special anchoring measurements.

