

CMA



Single inlet medium pressure centrifugal fans with cast aluminum casing and impeller



Fan:

- Cast aluminium casing.
- Cast aluminium impeller.
- Models 324, 325 and 426 impeller in polyamide, model 531-2T-3 impeller in sheet steel.

Motor:

- Motors with IE3 efficiency for powers equal to or greater than 0.75kW, except single-phase, 2-speed and 8-pole.
- Class F motors with ball bearings and IP55 protection except single-phase models with IP54 protection.
- Single-phase 230V 50 Hz and three-phase 230/400V 50 Hz.
- Maximum temperature of air to be carried: -20 °C +120 °C, maximum +70 °C models with polyamide impeller.

Finishing:

- Anti-corrosive finish in polyester resin, polymerised at 190 °C, after degreasing with phosphate-free nanotechnology treatment.

On request:

- Special windings for different voltages.
- Cast aluminium impellers for models 324, 325 and 426.
- Fan prepared to transport air up to +250 °C.
- Category 2 ATEX certification (see CMA/ATEX series).



Different options for impulsion positions

Order code



CMA: Single inlet medium pressure centrifugal fans with cast aluminum casing and impeller

Impeller size

Number of motor poles
2=2900 r/min 50 Hz

T=Three-phase
M=Single-phase

Motor power (HP)

Technical characteristics

Model	Speed (r/min)	Maximum admissible current (A)		Installed power (kW)	Maximum flow rate m ³ /h	Sound pressure level dB (A)	Approx. weight (Kg)	According ErP
		230V	400V					
CMA-218-2T	2670	0.64	0.37	0.09	265	63	6	Excluded
CMA-218-2M	2760	0.79		0.09	265	63	6	Excluded
CMA-324-2T	2750	1.21	0.70	0.18	440	70	9	2015
CMA-324-2M	2780	1.42		0.18	440	70	9	2015
CMA-325-2T	2710	1.29	0.75	0.25	600	73	11	2015
CMA-325-2M	2780	1.84		0.25	600	73	11	2015
CMA-426-2T	2710	1.92	1.11	0.37	850	75	13	2015
CMA-426-2M	2780	2.53		0.37	850	75	13	2015
CMA-527-2T	2760	2.57	1.49	0.55	1000	80	15	2015
CMA-527-2M	2810	3.49		0.55	1000	80	15	2015
CMA-528-2T-1 IE3	2825	2.80	1.62	0.75	1250	82	29	2015
CMA-528-2M-1	2810	4.50		0.75	1250	82	24	2015
CMA-528-2T-1.5 IE3	2830	4.03	2.34	1.10	1750	83	27	2015
CMA-528-2M-1.5	2820	6.51		1.10	1750	83	26	2015
CMA-531-2T-1.5 IE3	2830	4.03	2.34	1.10	1790	84	30	2015
CMA-531-2M-1.5	2820	6.51		1.10	1790	84	29	2015
CMA-531-2T-2 IE3	2875	5.34	3.07	1.50	2000	85	35	2015
CMA-531-2M-2	2810	8.50		1.50	2000	85	31	2015
CMA-531-2T-3 IE3	2910	7.32	4.21	2.20	2400	86	35	2015
CMA-540-2T IE3	2875	5.34	3.07	1.50	2600	85	42	2015
CMA-545-2T-3 IE3	2910	7.32	4.21	2.20	2630	86	59	2015
CMA-545-2T-4 IE3	2910	10.00	5.77	3.00	3550	88	68	2015

SMALL SERIES



Erp. (Energy Related Products)

Information on Directive 2009/125/EC can be downloaded from the SODECA website or the QuickFan selector programme.

Acoustic characteristics

Sound power spectrum Lw(A) in dB(A) per Hz frequency band

Model	63	125	250	500	1000	2000	4000	8000	Model	63	125	250	500	1000	2000	4000	8000
218	29	43	61	67	71	68	63	54	531-1.5	50	64	82	88	92	89	84	75
324	36	50	68	74	78	75	70	61	531-2	51	65	83	89	93	90	85	76
325	39	53	71	77	81	78	73	64	531-3	52	66	84	90	94	91	86	77
426	41	55	73	79	83	80	75	66	540	54	67	85	91	96	92	87	79
527	46	60	78	84	88	85	80	71	545-3	55	68	86	92	97	93	88	80
528-1	48	62	80	86	90	87	82	73	545-4	57	70	88	94	99	95	90	82
528-1.5	49	63	81	87	91	88	83	74									

Dimensions mm

CMA-218...528

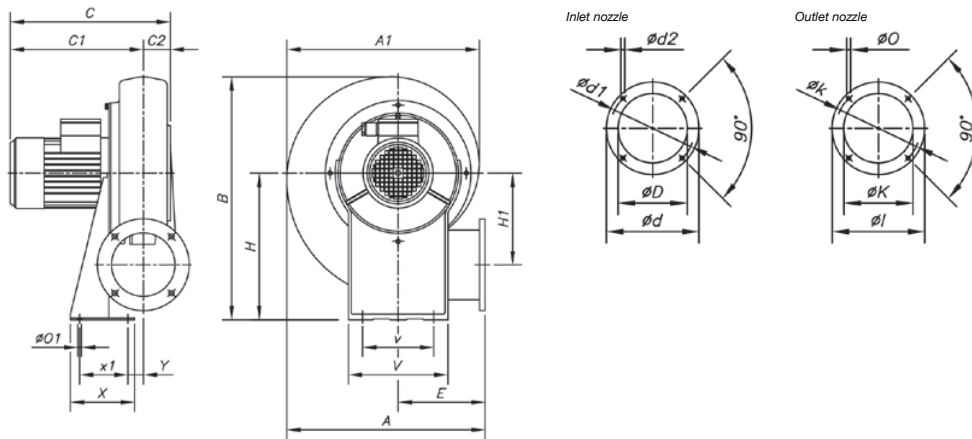

	A	A1	B	C	C1	C2	øD	ød	ød1	ød2	E	H	H1	øl	øK	øk	øO	øO1	V	v	X	x1	Y
CMA-218	241	236	288	239	207	32	80	113	95	M5	110	170	114.5	90	54	76	5.5	7	140	100	80	50	20
CMA-324	311	302	356	268	230	38	80	130	112	M5	145	205	145	108	62	90	7	9	173	125	90	60	20
CMA-325	335	328	399	271	231	40	94	140	122	M6	155	235	152	120	80	102	7	9	180	145	110	80	20
CMA-426	354	344	412	290	250	40	117	155	132	M6	162	240	163	140	90	119	7	13	210	160	105	65	26
CMA-527	371	361	440	297	255	42	125	170	147	M6	168	260	170	155	100	129	7	13	220	170	120	80	20
CMA-528...1	401	395	488	340	289	51	116	190	162	M6	178	290	177	190	130	160	11	13	230	180	140	100	20
CMA-528...1'5	401	395	488	337	289	48	135	190	162	M6	178	290	177	190	130	160	11	13	230	180	140	100	20

CMA-531

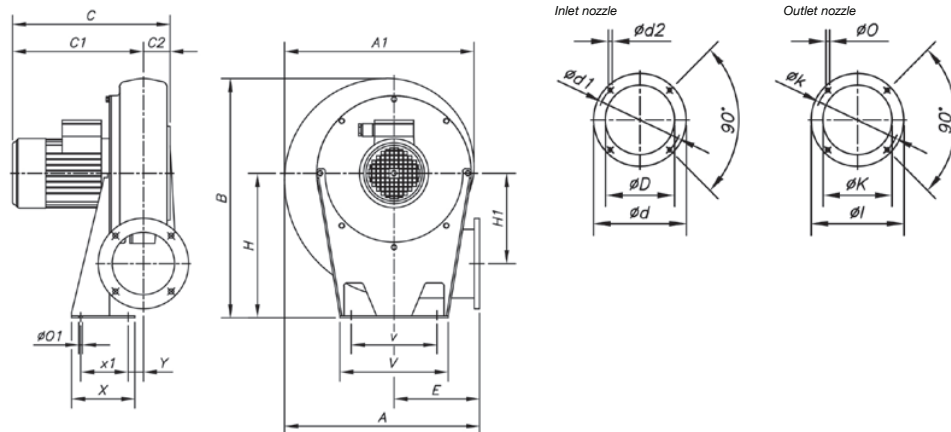

	A	A1	B	C	C1	C2	øD	ød	ød1	ød2	E	H	H1	øl	øK	øk	øO	øO1	V	v	X	x1	Y
CMA-531...1'5	440	434	537	340	290	50	160	215	180	M6	193	320	200	200	140	175	11	13	226	190	160	120	21
CMA-531...2	440	434	537	401	351	50	160	215	180	M6	193	320	200	200	140	175	11	13	226	190	160	120	21
CMA-531...3	440	434	537	401	351	50	160	215	180	M6	193	320	200	200	140	175	11	13	226	190	160	120	21

SMALL SERIES

INDUSTRIAL FANS · GENERAL CATALOGUE ·

Dimensions mm

CMA-540...545

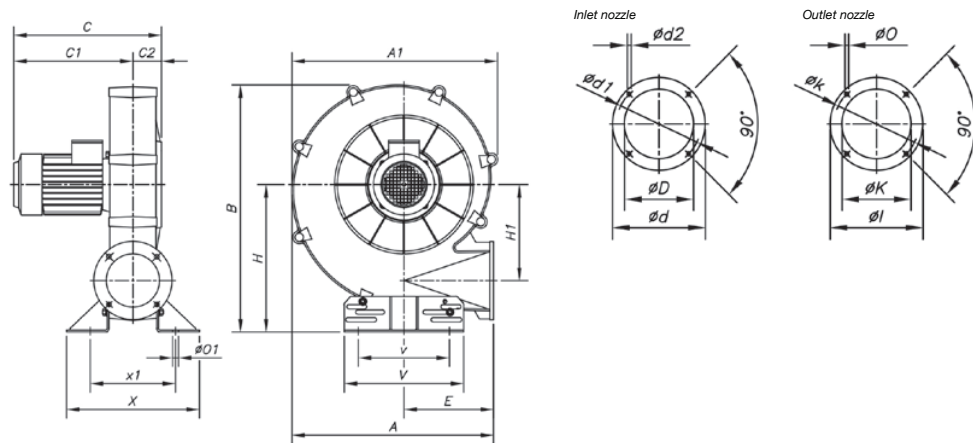

	A	A1	B	C	C1	C2	øD	ød	ød1	ød2	E	H	H1	øl	øK	øk	øO	øO1	V	v	X	x1
CMA-540	567	580	695	403	323	80	170	240	205	M10	252	415	270	220	150	190	13	11	336	218	374	240
CMA-545...3	651	646	776	449	334	115	180	255	220	M10	290	450	309	250	175	220	13	13	336	238	392	292
CMA-545...4	651	646	776	468	353	115	180	255	220	M10	290	450	309	250	175	220	13	13	336	238	392	292

Characteristic curves

Q= Flow rate in m³/h, m³/s and cfm Pe= Static pressure in mm H₂O, Pa and inwg

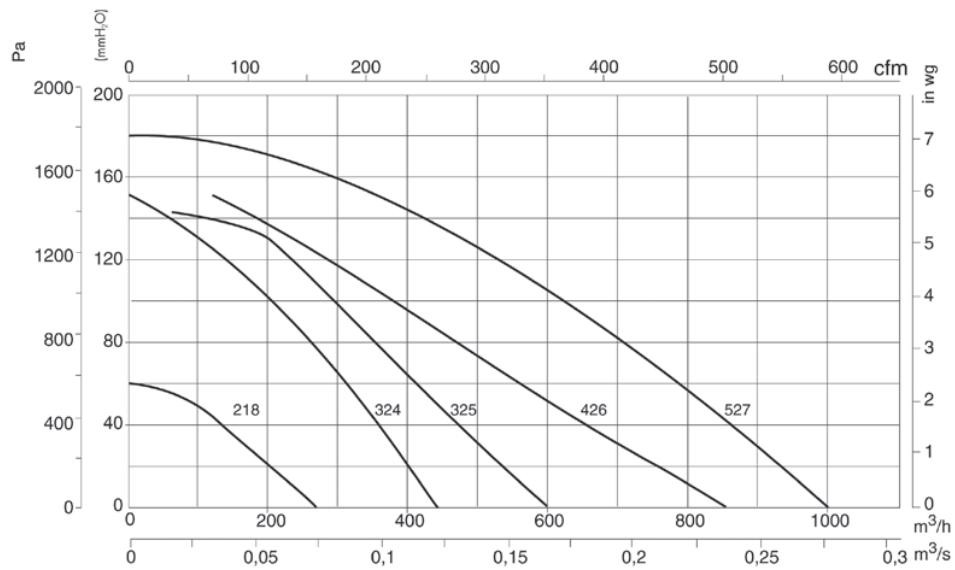

SMALL SERIES

Characteristic curves

Q= Flow rate in m³/h, m³/s and cfm Pe= Static pressure in mm H₂O, Pa and inwg

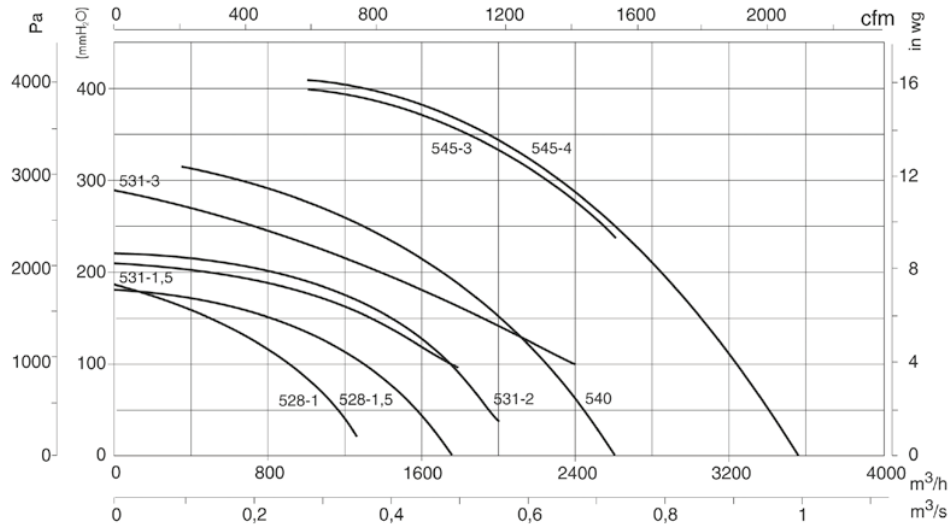

Orientations

Standard supply LG 270
LG 180 position on request and with special anchoring measurements.

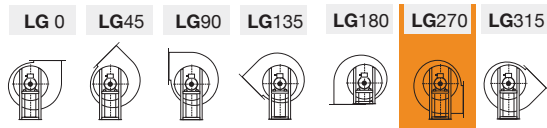

Accessories

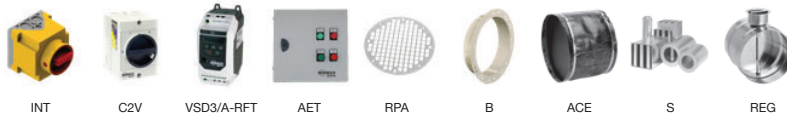

SMALL SERIES