

CMR

Very robust single inlet, medium pressure centrifugal fans, equipped with a backward curved impeller



Fan:

- Sheet steel casing.
- Backward curved impeller in highly robust sheet steel.

Motor:

- Motors with IE3 efficiency for powers equal to or greater than 0.75kW, except single-phase, 2-speed and 8-pole.
- Class F motors with ball bearings, IP55 protection.
- Three-phase 230/400 V 50 Hz (up to 4 kW) and 400/690 V 50 Hz (powers greater than 4 kW).
- Maximum temperature of air to be carried: -20 °C +120 °C.

Finishing:

- Anti-corrosive finish in polyester resin, polymerised at 190 °C, after degreasing with phosphate-free nanotechnology treatment.

On request:

- Special windings for different voltages.
- Fan prepared to transport air up to +250 °C.
- Stainless steel fan.
- Category 2 ATEX certification (see CMR/ATEX series).

Order code

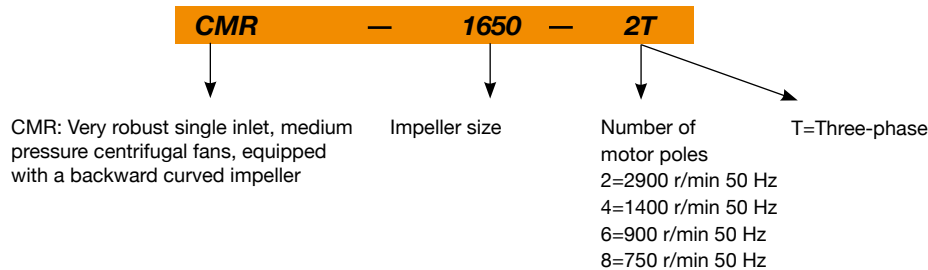

Technical characteristics

Model	Speed (r/min)	Maximum admissible current (A)			Installed power (kW)	Maximum flow rate (m³/h)	Sound pressure level dB(A)	Approx. weight (Kg)	According ErP
		230V	400V	690V					
CMR-1031-2T IE3	2875	5.34	3.07		1.50	5160	80	48	2015
CMR-1135-2T IE3	2910	7.32	4.21		2.20	7800	83	59	2015
CMR-1240-2T IE3	2900	13.00	7.50		4.00	11100	86	103	2015
CMR-1240-4T IE3	1420	2.82	1.62		0.75	5800	71	72	2015
CMR-1445-2T IE3	2930		14.10	8.17	7.50	16500	87	122	2015
CMR-1445-4T IE3	1455	4.07	2.34		1.10	8030	72	97	2015
CMR-1650-2T IE3	2945		20.00	11.60	11.00	18850	89	210	2015
CMR-1650-4T IE3	1440	5.41	3.11		1.50	10500	74	122	2015
CMR-1856-4T IE3	1440	10.70	6.15		3.00	15150	79	157	2015
CMR-2063-4T IE3	1465		10.30	5.97	5.50	24450	80	249	2015
CMR-2063-6T IE3	950	6.43	3.70		1.50	16100	71	212	2015
CMR-2271-4T IE3	1470		20.90	12.10	11.00	34610	85	340	2015
CMR-2271-6T IE3	970	12.00	6.91		3.00	22750	76	294	2015
CMR-2380-4T IE3	1470		41.00	23.80	22.00	48000	83	431	2015
CMR-2380-6T IE3	975		14.80	8.58	7.50	30000	75	398	2015

INDUSTRIAL FANS · GENERAL CATALOGUE ·



Erp. (Energy Related Products)

Information on Directive 2009/125/EC can be downloaded from the SODECA website or the QuickFan selector programme.

Acoustic characteristics

The indicated values are determined by measuring the sound pressure level and sound power in dB(A) obtained in a free field at a distance equivalent to twice the size of the fan plus the impeller diameter, with a minimum of 1.5 m.

Sound power spectrum Lw(A) in dB(A) per Hz frequency band.

Model	63	125	250	500	1000	2000	4000	8000	Model	63	125	250	500	1000	2000	4000	8000
1031-2	65	78	78	91	86	86	86	79	1856-4	69	78	91	87	90	91	85	71
1135-2	72	79	77	89	87	93	92	79	2063-4	80	85	91	93	91	88	81	73
1240-2	68	83	81	93	90	94	96	83	2063-6	69	70	82	82	81	83	73	63
1240-4	56	70	76	79	79	80	70	59	2271-4	83	84	93	96	98	99	95	82
1445-2	73	85	83	95	93	97	99	89	2271-6	73	73	87	86	90	90	79	68
1445-4	59	72	78	83	80	83	78	64	2380-4	76	78	94	91	96	97	93	82
1650-2	73	81	85	99	97	99	99	88	2380-6	68	70	86	83	88	89	85	74
1650-4	64	74	82	84	83	85	76	66									

Dimensions mm

CMR-1031...2271

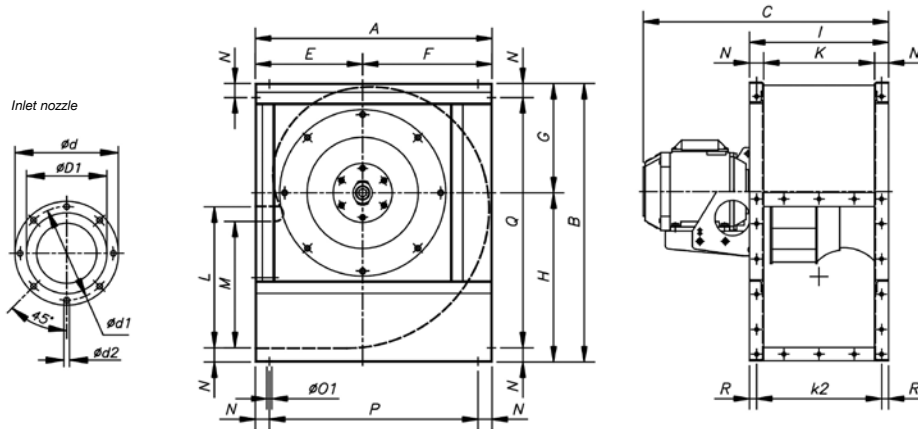

	A	B	C	øD1*	ød	ød1	ød2	E	F	G	H	I	K	k2	L	M	N	øO1	P	Q	R
CMR-1031-2T	542	626	573.5	315	383	356	M8	250	292	245	381	320	250	285	315	276	35	11	472	556	17.5
CMR-1135-2T	600	696	656	355	425	398	M8	275	325	273	423	350	280	315	355	310	35	11	530	626	17.5
CMR-1240-2T	673	790	728	400	472	444	M10	305	368	310	480	395	315	355	400	358	40	11	593	710	20
CMR-1240-4T	673	790	590	400	472	444	M10	305	368	310	480	395	315	355	400	358	40	11	593	710	20
CMR-1445-2T	765	880	810	450	522	494	M10	350	415	339	541	445	355	403	450	404	45	11	675	790	21
CMR-1445-4T	765	880	649	450	522	494	M10	350	415	339	541	445	355	403	450	404	45	11	675	790	21
CMR-1650-2T	832	970	961	500	582	555	M10	375	457	378	592	490	400	450	500	445	45	13	742	880	20
CMR-1650-4T	832	970	715	500	582	555	M10	375	457	378	592	490	400	450	500	445	45	13	742	880	20
CMR-1856-4T	925	1084	832	560	645	615	M10	415	510	426	658	550	450	500	560	493	50	13	825	984	25
CMR-2063-4T	1037	1218	973	630	720	688	M10	465	572	477	741	620	500	560	630	530	60	13	917	1098	30
CMR-2063-6T	1037	1218	893	630	720	688	M10	465	572	477	741	620	500	560	630	530	60	13	917	1098	30
CMR-2271-4T	1173	1375	1126	710	800	768	M12	525	648	538	837	690	560	625	710	603	65	13	1043	1245	32.5
CMR-2271-6T	1173	1375	1039	710	800	768	M12	525	648	538	837	690	560	625	710	603	65	13	1043	1245	32.5

* Recommended nominal tube diameter

SMALL SERIES

Dimensions mm

CMR-2380

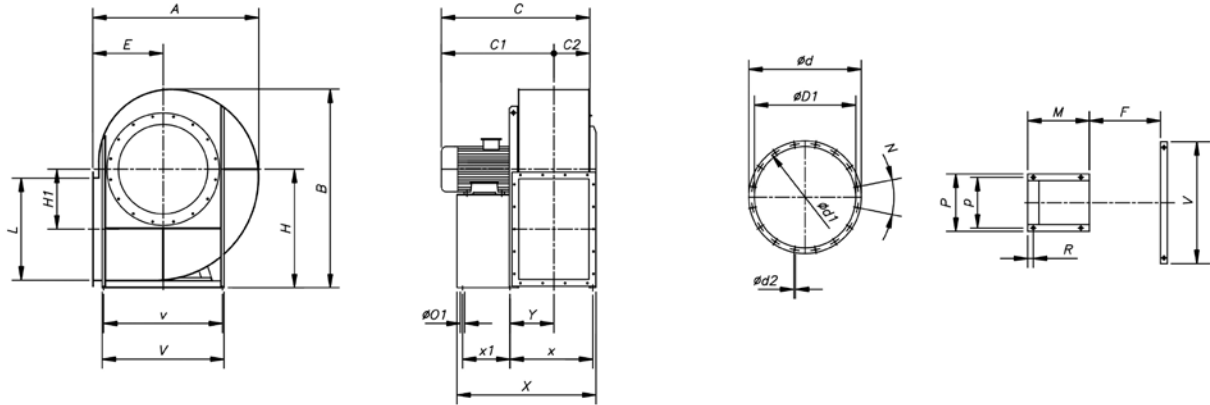

	A	B	C	C1	C2	ØD1	Ød	Ød1	Ød2	E	H	H1	L	F	M	R	N	Ø01	P
CMR-2380-4T	1312	1592	1174	882	292	805	920	861	15	560	950	482	808	574	543	39	16x22°30'	19	926
CMR-2380-6T	1312	1592	1055	763	292	805	920	861	15	560	950	482	808	574	474	39	16x22°30'	19	926

	p	V	v	X	x	x1	Y
CMR-2380-4T	862	965	862	1184	675	441	353
CMR-2380-6T	862	965	862	1115	675	372	353

Outlet nozzle

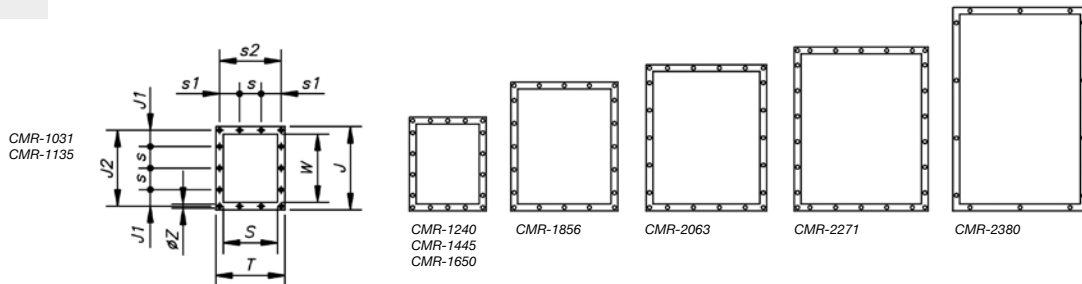

	T	J	J1	J2	S	s	s1	s2	W	Øz
CMR-1031	320	385	75	350	250	100	92.5	285	315	9
CMR-1135	350	425	95	390	280	100	107.5	315	355	9
CMR-1240	395	480	70	440	315	100	77.5	355	400	11
CMR-1445	445	540	99	498	355	100	102.5	403	450	11
CMR-1650	490	590	88	550	400	125	100	450	500	11
CMR-1856	550	660	55	610	450	125	125	500	560	13
CMR-2063	620	750	95	690	500	125	92.5	560	630	13
CMR-2271	690	840	75	775	560	125	62.5	625	710	13
CMR-2380	689	921	135	871	574	200	119	639	808	14

INDUSTRIAL FANS · GENERAL CATALOGUE ·

Characteristic curves

Q= Flow rate in m³/h, m³/s and cfm

Pe= Static pressure in mm H₂O, Pa and inwg

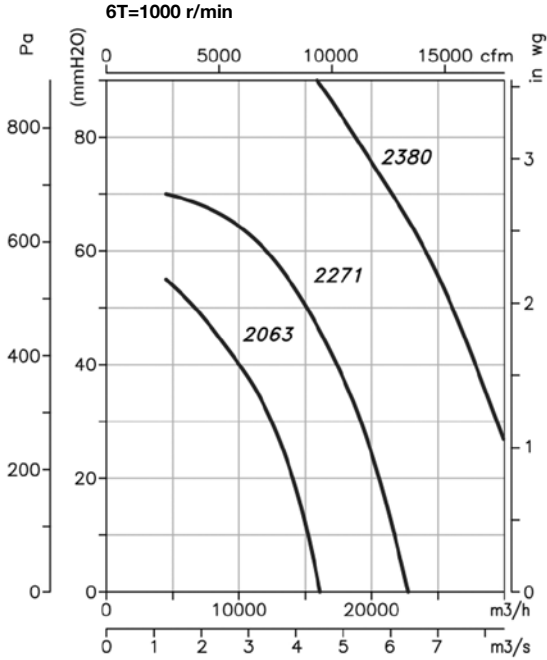
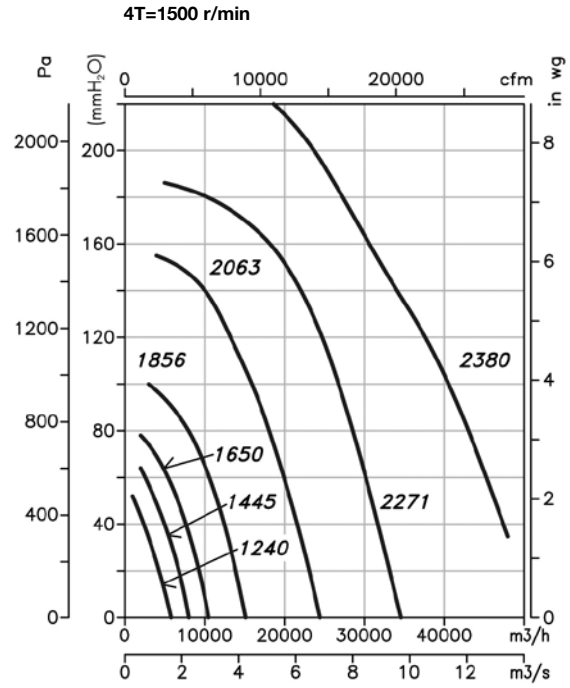
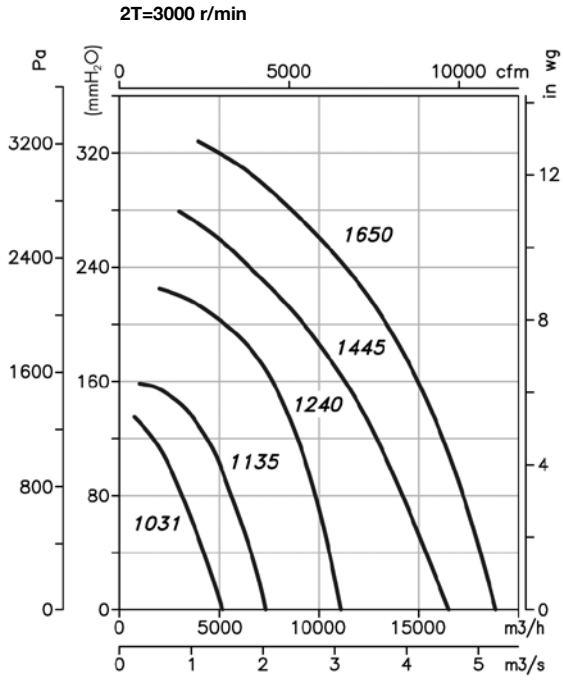

SMALL SERIES

Orientations

Standard supply LG 270

Models 2380, 2590 and 28100 with LG 270 fixed orientation (other orientations only on request)

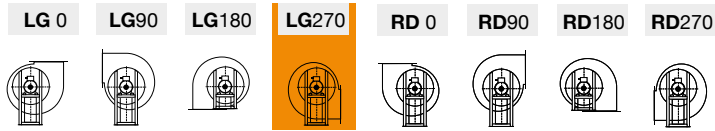

Accessories

